



**AC 8P**



**SIZE :**

80x80x25mm (3.15"x3.15"x0.98")

**CONSTRUCTION :**

- Die-cast aluminum housing
- Glass fiber reinforced plastic:  
Impeller are UL 94V-0 rating
- Impedance protected
- Leader wire or Terminal is available

**OPERATING TEMPERATURE :**

Ball bearing - 30°C to +75°C

Sleeve bearing - 10°C to +70°C

**WEIGHT :**

260 grams

**Specifications**

Specifications are subject to change without notice

MODEL NO.	BEARING	RATED VOLTAGE	FREQUENCY	MAX. RATED CURRENT	MAX. INPUT POWER	SPEED	MAX. AIR FLOW		MAX. AIR PRESSURE		NOISE
		VAC	Hz	mA	W	R.P.M.	m <sup>3</sup> /min	CFM	mmH <sub>2</sub> O	IN H <sub>2</sub> O	dB-A
8P-115LB	Ball	115	50/60	140/130	14/13	1900/2400	0.4/0.5	13.8/17.5	2.1/3.2	0.1/0.1	21/25
8P-115LS	Sleeve										
8P-115HB	Ball	115	50/60	150/140	16/14	2500/3000	0.5/0.6	17.3/21.0	3.1/4.4	0.1/0.2	30/35
8P-115HS	Sleeve										
8P-200HB	Ball	200	50/60	130/120	21/18	2500/3000	0.5/0.6	17.3/21.0	3.1/4.4	0.1/0.2	30/32
8P-230LB	Ball	230	50/60	80/70	16/15	1900/2400	0.4/0.5	13.8/17.5	2.1/3.2	0.1/0.1	21/25
8P-230LS	Sleeve										
8P-230HB	Ball	230	50/60	95/85	18/16	2500/3000	0.5/0.6	17.3/21.0	3.1/4.4	0.1/0.2	30/35
8P-230HS	Sleeve										

**Dimensions (mm)**

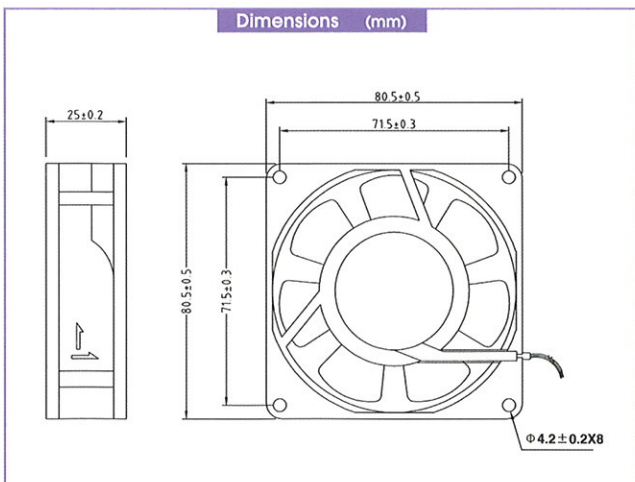

**Performance Curve**

